

1.5.10.2 MGW

MGW7, MGW9, MGW12

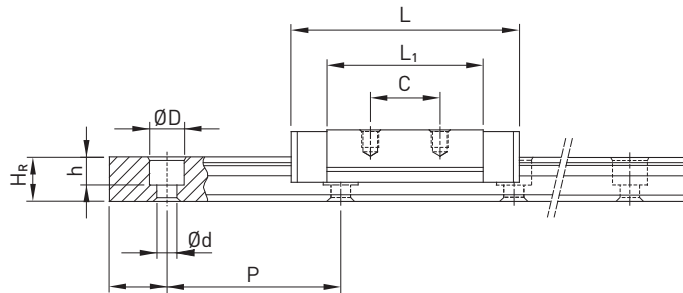

MGW15

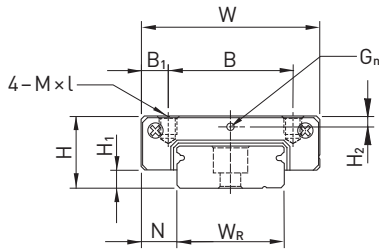
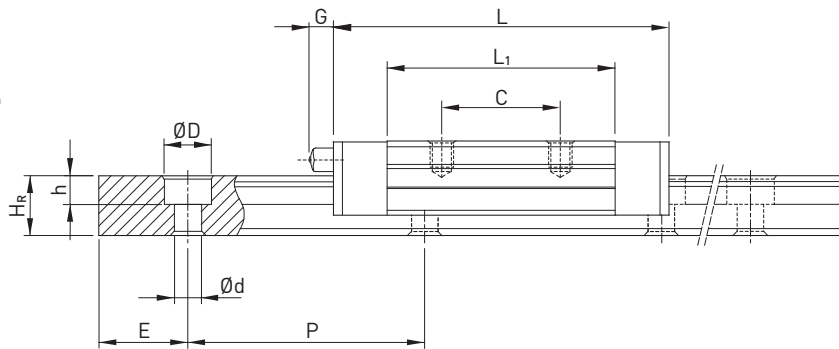
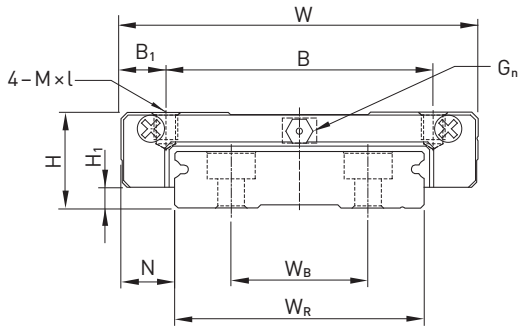

Table 1.67 Dimensions of the block

Series Size	Installation dimensions [mm]			Dimensions of the block [mm]										Load Ratings [N]		Mass [kg]
	H	H ₁	N	W	B	B ₁	C	L ₁	L	G	G _n	M × l	H ₂	C _{dyn}	C ₀	
MGW07C	9	1,9	5,5	25	19	3	10	21	31,2	—	Ø1,2	M3 × 3	1,85	1370	2060	0,02
MGW07H							19	30,8	41					1770	3140	0,03
MGW09C	12	2,9	6,0	30	21	4,5	12	27,5	39,3	—	Ø1,4	M3 × 3	2,4	2750	4120	0,04
MGW09H					23	3,5	24	38,5	50,7					3430	5890	0,06
MGW12C	14	3,4	8,0	40	28	6	15	31,3	46,1	—	Ø2	M3 × 3,6	2,8	3920	5590	0,07
MGW12H							28	45,6	60,4					5100	8240	0,10
MGW15C	16	3,4	9,0	60	45	7,5	20	38	54,8	5,2	M3	M4 × 4,2	3,2	6770	9220	0,14
MGW15H							35	57	73,8					8930	13380	0,22

Dimensions of the rail see page 57, standard and optional lubrication adapters see page 86.